

## SDBV Series Ball Valves for DIN Standard

### Features

- Pressure rating up to 500barg @ 21°C
- Temperature rating from -20°C to 100°C with POM and FKM(Viton) standard.
- Conforms to DIN standard.
- Compact design with maximum orifice.
- Variety of end connections such as DIN 2353 “L” & “S” series, Male & Female DIN / ISO/ BSP and NPT threads.
- Handle is only available in cast stainless steel standard.
- Every valve is 100% factory tested with the Nitrogen @1,000psig (68barg)

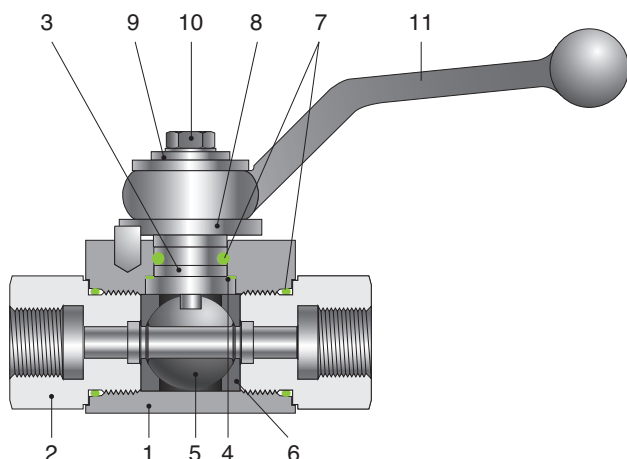

### Materials of Construction

Description	Grade / Specification
1 Body	S316/A479 or A276 DIN 17440/14571
2 End Connector	
3 Stem	
4 Stem Bearing	PTFE
5 Ball	S316/A479 or A276 DIN 17440/14571
6 Ball Seats	POM – MoS2 (Standard)
7 Stem & End Seals	Fluorocarbon FKM O-ring
8 Locking Device	Stainless Steel
9 Upper Washer	Stainless Steel
10 Bolt	Stainless Steel
11 Handle	S316

### Temperature Rating

#### Seals

Materials	Temperature Rating
NBR	-23 °C to 121 °C
FKM	-23 °C to 200 °C
EPDM	-46 °C to 149 °C

#### Ball Seats

Materials	Temperature Rating
POM – MoS2	-30 °C to 100 °C
PTFE	-54 °C to 65 °C

### Test

- Every valve is factory tested with bubble-tight leakage test at both seat and stem packing with nitrogen at 1,000psig (69barg)
- Hydraulic shell test is performed at 1.5 times the working pressure.
- Seats have a maximum allowable leakage rate of 0.1 SCCM Optional tests are available upon request

### Safety in Valve Selection

When selecting a valve, the total system design must be considered to ensure safe, trouble-free performance. Valve function, materials compatibility, adequate ratings, proper installation, operation, and maintenance are the responsibility of the system designer and user.

## Product Information

### Table of Dimensions

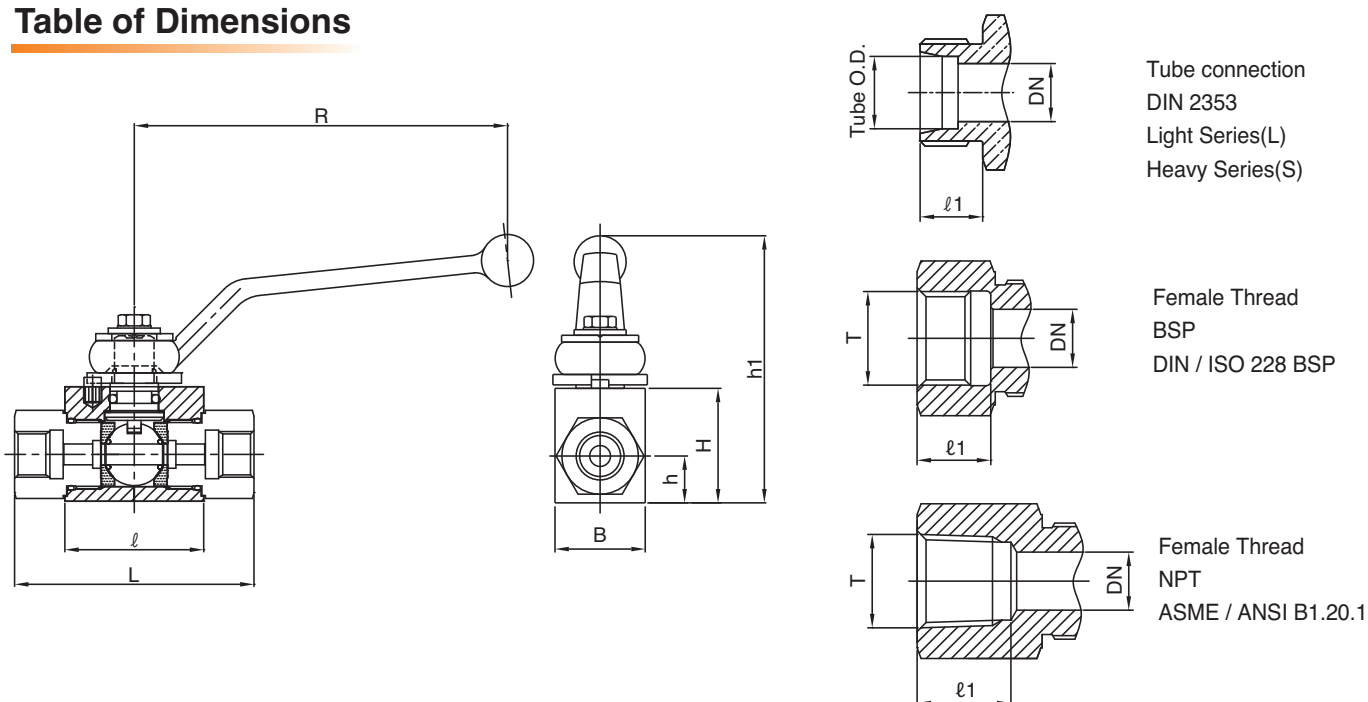

#### DIN 2353 Light(L) Tube Series

Basic Ordering Number	End Connections Inlet & Outlet	DN	PB	Dimensions (mm)								Weight (kg)
				B	H	h	h1	L	l	l1	R	
SDBV1 – 6L	6MM	4	315	26	33	13.5	82	67	40	10	115	0.4
SDBV1 – 8L	8MM	6	315	26	33	13.5	82	67	40	10	115	0.4
SDBV1 – 10L	10MM	6	315	26	33	13.5	82	74	40	11	115	0.5
SDBV2 – 12L	12MM	10	315	32	38	17.5	87	74	43	11	115	0.6
SDBV3 – 15L	15MM	13	315	35	40	19	89	82	48	12	115	0.7
SDBV3 – 18L	18MM	13	315	35	40	19	89	82	48	12	115	0.8
SDBV4 – 22L	22MM	20	160	49	57	24.5	114	101	62	14	159	2.1
SDBV5 – 28L	28MM	25	160	58	65	29.5	122	108	66.2	14	159	2.3
SDBV5 – 35L	35MM	25	160	58	65	29.5	122	112	66.2	16	159	2.3

#### DIN 2353 Heavy (S) Tube Series

Basic Ordering Number	End Connections Inlet & Outlet	DN	PB	Dimensions (mm)								Weight (kg)
				B	H	h	h1	L	l	l1	R	
SDBV1 – 8S	8MM	4	500	26	33	13.5	82	73	40	12	115	0.4
SDBV1 – 10S	10MM	6	500	26	33	13.5	82	73	40	12	115	0.4
SDBV2 – 12S	12MM	6	500	32	38	13.5	82	76	43	12	115	0.5
SDBV2 – 14S	14MM	10	500	32	38	17.5	87	80	43	14	115	0.6
SDBV3 – 16S	16MM	13	400	35	40	19	89	86	48	14	115	0.7
SDBV3 – 20S	20MM	13	400	35	40	19	89	90	48	16	115	0.8
SDBV4 – 25S	25MM	20	315	49	57	24.5	114	109	62	18	159	2.1
SDBV5 – 30S	30MM	25	315	58	65	29.5	122	120	66.2	20	159	2.3
SDBV5 – 38S	38MM	25	315	58	65	29.5	122	124	66.2	22	159	2.3

## Product Information

### Female DIN / ISO 228 / BSP

Basic Ordering Number	End Connections Inlet & Outlet	DN	PB	Dimensions (mm)								Weight (kg)
				B	H	h	h1	L	ℓ	ℓ1	R	
SDBV1-F-2G	PF 1/8	6	500	26	33	13.5	82	68.8	40	10	115	0.4
SDBV1-F-4G	PF 1/4	6	500	26	33	13.5	82	68.8	40	14	115	0.4
SDBV2-F-6G	PF 3/8	10	500	32	38	17.5	87	71.9	43	14	115	0.6
SDBV3-F-8G	PF 1/2	13	500	35	40	19	89	82.3	48	16.5	115	0.7
SDBV4-F-12G	PF 3/4	20	315	49	57	24.5	114	95.4	62	18	159	1.6
SDBV5-F-16G	PF 1	25	315	58	65	29.5	122	112.7	66.2	20	159	2.3
SDBV6-F-20G	PF1 1/4	32	315	75	82	37.5	165	121.6	68	22	260	4.36
SDBV7-F-24G	PF 1 1/2	38	315	95	99.1	47.5	182	130.2	85	24	260	6.8
SDBV8-F-32G	PF 2	50	315	115	115.2	57.5	198	140	100	26	260	9.44

### Female NPT (ANSI/ASME B1.20.1)

Basic Ordering Number	End Connections Inlet & Outlet	DN	PB	Dimensions (mm)								Weight (kg)
				B	H	h	h1	L	ℓ	ℓ1	R	
SDBV1-F-4N	NPT 1/4	6	500	26	33	13.5	82	68.8	40	15	115	0.4
SDBV2-F-6N	NPT 3/8	10	500	32	38	17.5	87	78	43	15	115	0.6
SDBV3-F-8N	NPT 1/2	13	500	35	40	19	89	104	48	20.5	115	0.7
SDBV4-F-12N	NPT 3/4	20	315	49	57	24.5	114	102	62	21.5	159	1.6
SDBV5-F-16N	NPT 1	25	315	58	65	29.5	122	119	66.2	25.4	159	2.3
SDBV6-F-20N	NPT 1 1/4	32	315	75	82	37.5	165	-	68	-	260	-
SDBV7-F-24N	NPT 1 1/2	38	315	95	99.1	47.5	182	-	85	-	260	-
SDBV8-F-32N	NPT 2	50	315	115	115.2	57.5	198	-	100	-	260	-

## Applications

- Hydraulic fluids, compressed air, lubricants, and fuel oil system.

## Sour Gas Service

- Is provided to meet NACE Standard MR0175.

## Ordering Information

- Selection of the applicable options from the designators are listed below.

<b>SDBV3</b>	<b>F</b>	<b>4G</b>	<b>TE</b>	<b>NB</b>	<b>LD</b>	<b>SG</b>	<b>S6</b>
Basic Ordering Number	End Connection Designator	Size Designator	Ball Seat Material Designator	Stem & End Seal Material Designator	Locking Device Designator	Sour Gas Designator	Material Designator
	<ul style="list-style-type: none"> <li>F : Female Thread</li> <li>M : Male Thread</li> <li>T : Tube Connection</li> </ul>		<ul style="list-style-type: none"> <li>Nil : Standard POM-MoS2</li> <li>TE : PTFE</li> </ul>	<ul style="list-style-type: none"> <li>Nil : Standard FKM</li> <li>NB : NBR</li> <li>EP : EPDM</li> </ul>	<ul style="list-style-type: none"> <li>Nil : Without (Standard)</li> <li>LD : With</li> </ul>	<ul style="list-style-type: none"> <li>Nil : Without (Standard)</li> <li>SG : Sour Gas</li> </ul>	<ul style="list-style-type: none"> <li>S6 : S316</li> <li>CS : Carbon Steel</li> </ul>